

Diffractive Variable Attenuators for High Power Lasers

Diffractive attenuators control the power of laser radiation using diffraction gratings. Since phase diffraction gratings do not absorb light they can be used for high-power laser radiation (cw, pulsed). Variation of grating parameters along the attenuator results in variable transmission at a given wavelength. Diffractive attenuators can be designed for deep UV till IR.

1. Principle of operation

Light beam passing through a diffractive grating is partially deflected into several diffractive orders, subsequently blocked by diaphragm. Thus zero order beam (does not change the direction of propagation) is attenuated. The intensity of output radiation I_{output} depends on the grating design and wavelength. Grating parameters determine the power of output radiation. The transmission coefficient of such an attenuator is $h = I_{\text{output}}/I_{\text{input}}$. Transmission varies from h_{max} to h_{min} by 360° rotation of attenuator wheel. Attenuation range is defined as $D = h_{\text{max}}/h_{\text{min}}$.

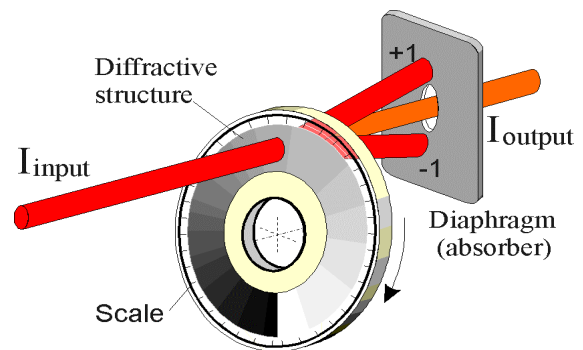

Principle operation scheme of high-power attenuator based on non-absorbing-phase diffractive gratings (etched in quartz).

2. Key features

- ▲ High power attenuator: Diffractive attenuators can control high power laser radiation, either pulsed or continuous (cw) laser beams due to non-absorbing phase gratings.
- ▲ Flexible design of transmission function: The dependence $h(j)$ of the attenuator transmission on rotation angle j can be designed by computer for customer's requirements.
- ▲ Low cost mass-fabrication: Laser lithographic methods allow one to produce attenuators by binary optics technology with significant price decrease for larger quantities.

3. Applications

- ▲ Beam-modulators for high power lasers (Nd:YAG-, Argon-, Excimer-...) → material processing, e.g. marking, scanner systems
- ▲ Beam-splitters with adjustable splitting coefficient and attenuation → laser-technology, photometry, optical research
- ▲ Holography: Intensity modulation of object/reference beam with neglectible wavefront distortion.

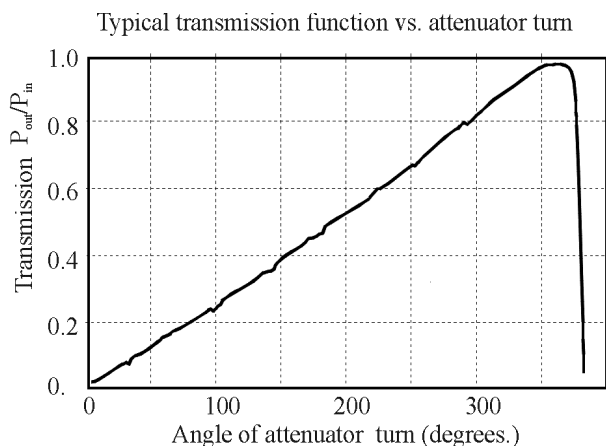

4. Specifications

Substrate

- material
- surface flatness
- wedge
- outside-, inside diameter
- thickness
- clear aperture
- front side
- back side

Design wavelength

- other wavelengths on request
- transmission range
- deviation from linearity
- polarization

Damage threshold

UV grade fused silica

$\lambda/4$ @ 532nm over clear aperture

≤ 30 arcsec

60 mm, 8mm

4 mm

10 mm

AR-coating, $R < 0.3\%$

diffractive grating (binary phase relief, 10 μ m)

266nm, 355nm, 532nm, 800nm, 1064nm

$T_{\text{linear}} = 2\% - 95\%$ over 340°

$\leq 5\%$

transmission not dependent on polarization!

≥ 500 W/cm² -cw, ≥ 2 J/cm² with 10ns pulses

5. Spectral response

Although diffractive attenuators are optimized for I_0 , they will operate over a larger spectral range ($I_0 \pm 15\%$) with minor attenuation range decreasing. Thus 532nm attenuator with attenuation value $D(\lambda_0) = 20$ can work at 633nm wavelength with $D = 10$. Functional dependence of transmission function is remained the same. Notice that attenuator works also at 1/3 of design wavelength I_0 , however has nearly zero effect at $I_0/2$.

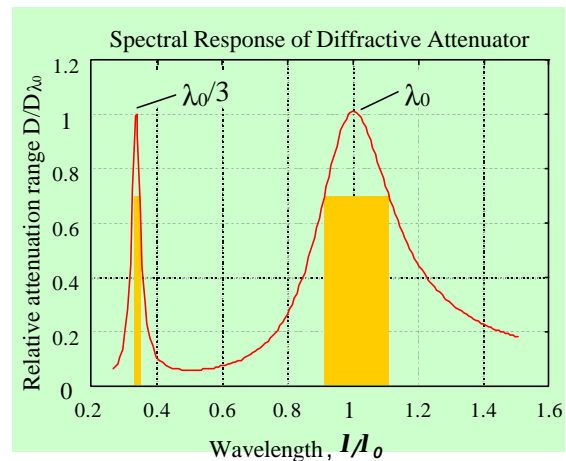

6. Attenuator Design and Operation

Attenuator includes diffractive attenuator wheel mounted in special holder and two tubes with maximum length of 108 mm (see figure). Tubes intend for blocking parasitic diffractive orders and absorbing of laser radiation. Tubes are suitable for less than 20 Watt average power dissipation. A special finned radiator is required for higher laser power.

